



ELECTRIC FIRE PUMP SPECIFICATION

MODEL : EFP-50.12.DEF

CAPACITY : 500 GPM

HEAD : 120 M



ELECTRIC MOTOR SPECIFICATION	
Model	DEF280S-2
Brand	Defender
Capacity (Gpm - M)	500 - 120
Phase - Frequency	3 phase - 50 hz
Speed	3000
Voltage	380
Power	75 kw - 100 Hp
Weight (kg)	300

PUMP SPECIFICATION	
Model	100 x 65 FSKA
Brand	Ebara
Inlet & Outlet (Inch)	4 x 2.5
Power Pump (Kw)	75
Speed (Rpm)	3000
Chasing	Cast Iron
Shaft	403 Stainless Steel
Seal	Ceramic/Carbon/NBR
Impeller	Bronze Casting (CAC406/BC60)
Weight (Kg)	250

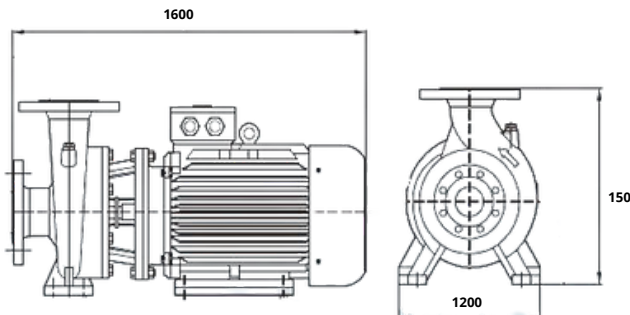

DIMENSION AND WEIGHT

- length (mm) : 1600
- Width (mm) : 1200
- Height (mm) : 150
- Net weighg (Kg) : +/- 550